

# TECHNICAL SPECIFICATIONS GX100 MTO 3SR

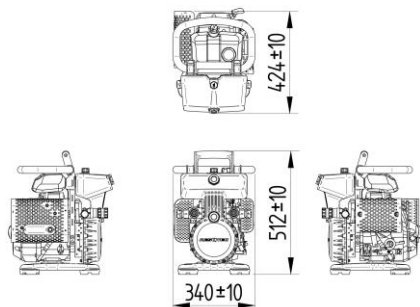

## GX100 MTO 3SR MIDI

NEO1 

HP/FF 

Nominal pressure	UltimatePressure™ 350 bar	UltimatePressure™ 350 bar
EN-13204 designation	MTO	MTO
+SMART auto speed regulator with manual override	No	No
Running time	Ca. 180 min	Ca. 180 min
Engine / power supply	Honda 2.1kW (2.8 HP) 4-stroke petrol	Honda 2.1kW (2.8 HP) 4-stroke petrol
Fuel tank capacity	0.77 liter	0.77 liter
Noise level at 1 meter distance (EN-13204)	Lpa 78 dB	Lpa 78 dB
NFPA emission sound level at 4 meter distance	Not applicable	Not applicable
Dimensions (L x W x H)	424 x 340 x 512 mm (±10 mm)	424 x 340 x 512 mm (±10 mm)
EN-13204 weight (ready use HF & fuel full)	28.6 kg (±0.2 kg)	29.3 kg (±0.2 kg)
Weight with HF but no fuel	27.9 kg (±0.2 kg)	28.6 kg (±0.2 kg)
Dry shipping weight (with motor oil)	24.9 kg (±0.2 kg)	25.6 kg (±0.2 kg)
Pump	3-stage radial piston	3-stage radial piston
Total hydraulic fluid capacity	3.8 liter	3.8 liter
Effective hydraulic fluid capacity	2.8 liter	2.8 liter
1st stage (0 – 120 bar)	2x 3,200 cc/min (3.2 l/min)	2x 3,200 cc/min (3.2 l/min)
2nd stage (120 – 240 bar)	2x 1,972 cc/min (2.0 l/min)	2x 1,972 cc/min (2.0 l/min)
3rd stage (240 – 350 bar)	2x 986 cc/min (1.0 l/min)	2x 986 cc/min (1.0 l/min)

## ACCESSORIES

Art Nr.

LED light add-on	9500.1000
Elevation add-on 1,000-2,000m	3436.1020
Elevation add-on 2,000-3,000m	3436.2030



# TECHNICAL SPECIFICATIONS

# GX100 MTO 3SR +SMART

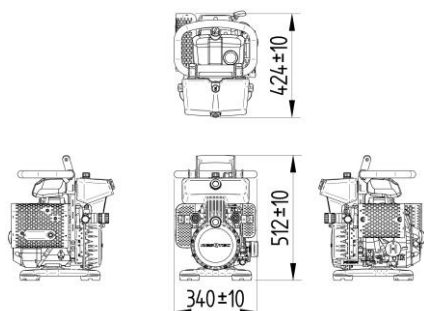

## GX100 MTO 3SR +SMART MIDI

NEO1 

HP/FF 

Nominal pressure	UltimatePressure™ 350 bar	UltimatePressure™ 350 bar
EN-13204 designation	MTO	MTO
+SMART auto speed regulator with manual override	Yes	Yes
Running time	Ca. 180 min	Ca. 180 min
Engine / power supply	Honda 2.1kW (2.8 HP) 4-stroke petrol	Honda 2.1kW (2.8 HP) 4-stroke petrol
Fuel tank capacity	0.77 liter	0.77 liter
Noise level at 1 meter distance (EN-13204)	Lpa 78 dB	Lpa 78 dB
Noise level at 1 meter distance (3,250 rpm)	Lpa 74 dB	Lpa 74 dB
Noise level at 1 meter distance (1,750 rpm)	Lpa 68 dB	Lpa 68 dB
NFPA emission sound level at 4 meter distance	Not applicable	Not applicable
Dimensions (L x W x H)	424 x 340 x 512 mm (±10 mm)	424 x 340 x 512 mm (±10 mm)
EN-13204 weight (ready use HF & fuel full)	29.5 kg (±0.2 kg)	30.2 kg (±0.2)
Weight with HF but no fuel	28.8 kg (±0.2 kg)	29.5 kg (±0.2)
Dry shipping weight (with motor oil)	25.8 kg (±0.2 kg)	26.5 kg (±0.2)
Pump	3-stage radial piston	3-stage radial piston
Total hydraulic fluid capacity	3.8 liter	3.8 liter
Effective hydraulic fluid capacity	2.8 liter	2.8 liter
1st stage (0 – 120 bar)	2x 3,200 cc/min (3.2 l/min)	2x 3200 cc/min (3.2 l/min)
2nd stage (120 – 240 bar)	2x 1,972 cc/min (2.0 l/min)	2x 1972 cc/min (2.0 l/min)
3rd stage (240 – 350 bar)	2x 986 cc/min (1.0 l/min)	2x 986 cc/min (1.0 l/min)

## ACCESSORIES

Art Nr.

LED light add-on	9500.1000
Elevation add-on 1,000-2,000m	3436.1020
Elevation add-on 2,000-3,000m	3436.2030

