

# TECHNICAL SPECIFICATIONS GX160S MTO

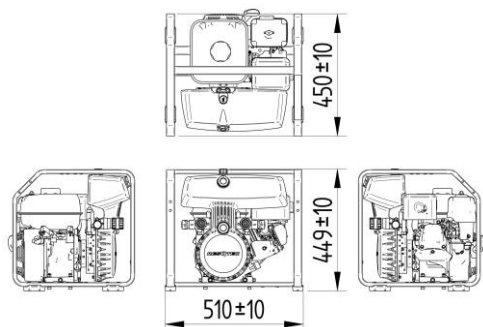

## GX160S MTO 3SR STD MAXI

NEO1 

HP/FF 

Nominal pressure	UltimatePressure™ 350 bar	UltimatePressure™ 350 bar
EN-13204 designation	MTO	MTO
+SMART auto speed regulator with manual override	No	No
Electric start & manual recoil start	No	No
Running time	Ca. 180 min	Ca. 180 min
Engine / power supply	Honda 3.6kW (4.8 HP) 4-stroke petrol	Honda 3.6kW (4.8 HP) 4-stroke petrol
Fuel tank capacity	3.1 liter	3.1 liter
Noise level at 1 meter distance (EN-13204)	Lpa 81 dB	Lpa 81 dB
NFPA emission sound level at 4 meter distance	Lpa 75 dB	Lpa 75 dB
Dimensions (L x W x H)	450 x 510 x 449 mm (±10 mm)	450 x 510 x 449 mm (±10 mm)
EN-13204 weight (ready use HF & fuel full)	40.0 kg (±0.2 kg)	40.7 kg (±0.2 kg)
Weight with HF but no fuel	38.2 kg (±0.2 kg)	38.9 kg (±0.2 kg)
Dry shipping weight (with motor oil)	33.9 kg (±0.2 kg)	34.6 kg (±0.2 kg)
Empty weight	33.5 kg (±0.2 kg)	34.2 kg (±0.2 kg)
Pump	3-stage radial piston	3-stage radial piston
Total hydraulic fluid capacity	4.9 liter	4.9 liter
Effective hydraulic fluid capacity	3.9 liter	3.9 liter
1st stage (0 – 120 bar)	2x 5,883 cc/min (5.9 l/min)	2x 5,883 cc/min (5.9 l/min)
2nd stage (120 – 220 bar)	2x 3,153 cc/min (3.2 l/min)	2x 3,153 cc/min (3.2 l/min)
3rd stage (220 – 350 bar)	2x 1,235 cc/min (1.2 l/min)	2x 1,235 cc/min (1.2 l/min)

## ACCESSORIES

Art. Nr.

## ACCESSORIES

Art. Nr.

LED light add-on	9500.1000
Fold-O-Matic carry handle add-on set 4	3455.0504
H-GX160 Fuel level indicator add-on	3425.0265

Elevation add-on 1,000-2,000m	3437.1020
Elevation add-on 2,000-3,000m	3437.2030
Elevation add-on 3,000-4,000m	3437.3040
Elevation add-on 4,000-5,000m	3437.4050



RESQTEC  
 ULTIMATE



Information contained in this document is believed to be accurate. However RESQTEC does not guarantee the completeness or accuracy of any of the published information.



RESQTEC Zumro B.V.  
 Meer en Duin 82 | 2163 HC Lisse, the Netherlands

T +31 (0)252 419002 F +31 (0)252 411794  
 E info@resqtec.com W www.resqtec.com

**RESQTEC**