

TECHNICAL SPECIFICATIONS SPREADER X4

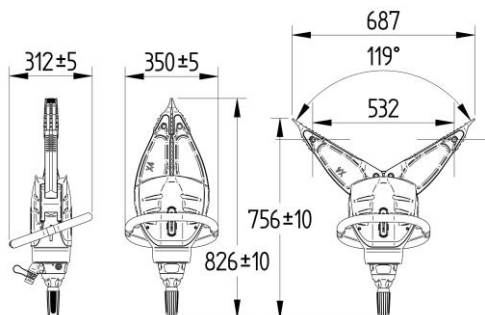

SPREADER X4

NEO1 

HP/FF 

Nominal pressure	UltimatePressure™ 350 bar	UltimatePressure™ 350 bar
Tailhose safety factor	-	8:1 (2,800 bar)
Dimensions (L x W x H)	826 x 350 x 312 mm	826 x 350 x 312 mm
Operational weight	21.2 kg	22.5 kg
Max. spreading opening	687 mm	687 mm
Spreading force at base of arm teeth ¹	102.7 – 3,474.0 kN / 10.5 - 354.2 ton	102.7 – 3,474.0 kN / 10.5 - 354.2 ton
Spreading force at base of jaw	71.8 - 213.6 kN / 7.3 - 21.8 ton	71.8 - 213.6 kN / 7.3 - 21.8 ton
Spreading force 25 mm from tips	53.0 - 91.0 kN / 5.4 - 9.3 ton	53.0 - 91.0 kN / 5.4 - 9.3 ton
NFPA HSF	82.3 kN / 8.4 ton	82.3 kN / 8.4 ton
NFPA LSF	49.4 kN / 5.0 ton	49.4 kN / 5.0 ton
Max. pulling opening	532 mm	532 mm
Pulling force	63.4 - 128.1 kN / 6.5 - 13.1 ton	63.4 - 128.1 kN / 6.5 - 13.1 ton
NFPA HPF	74.9 kN / 7.6 ton	74.9 kN / 7.6 ton
NFPA LPF	45.8 kN / 4.7 ton	45.8 kN / 4.7 ton
Squeezing force at base of arm teeth ¹	176.7 - 289.0 kN / 18.0 - 29.5 ton	176.7 - 289.0 kN / 18.0 - 29.5 ton
EN 13204	AS53-687-21.2	AS53-687-22.5
NFPA 1936	Compliant	Compliant

ACCESSORIES

Art. Nr.

LED light add-on	9500.1000
X-series chain & shackle set	2310.3000
X-series aircraft jaws set	2160.6125

¹Maximum is a theoretical force that cannot be measured.

All forces with EN13204 certified power pack with pressure relief valves set conform EN13204 allowable pressure requirements



Information contained in this document is believed to be accurate. However RESQTEC does not guarantee the completeness or accuracy of any of the published information.



RESQTEC Zumro B.V.
 Meer en Duin 82 | 2163 HC Lisse, the Netherlands

T +31 (0)252 419002
E info@resqtec.com

F +31 (0)252 411794
W www.resqtec.com

RESQTEC®